

Sustainability & Additive Manufacturing

Liz Scoffins

29/03/2022

Morning Overview

- Part 1: Sustainability for an AM Facility
Industrial Case Study
- Break
- Part 2: Future State for AM
Exercise
- Break
- Part 3: Sustainability in Design for AM

Introduction

- Liz Scoffins, MIMMM
- Research Engineer at the Manufacturing Technology Centre (MTC)
- Technology Transformation Team
- MEng in Materials Engineering



Sustainability & Additive Manufacturing

Learning Outcomes

- To review a case study of sustainability within an AM facility
- Understand the rationale for data collection in sustainability
- To have explored suggested future technology for sustainable AM

Morning Overview

- **Part 1: Sustainability for an AM Facility**
Industrial Case Study
- Break
- Part 2: Future State for AM
Exercise
- Break
- Part 3: Sustainability in Design for AM

Background

Part 1: Sustainability for an AM Facility

- Additive Manufacturing (AM) is a novel process where products are created by successively layering material to build up the final shape.
- It is a **growing area of technology innovation** and development with seven main techniques, which can be utilised within any industry.
- AM is repeatedly highlighted as a key pillar of industrial digitalisation and is **forecast to grow by a further 30%** in the next 8 years [1].
- MTC is at the forefront of AM technology and is home to the National Centre for Additive Manufacturing (NCAM) for the UK.

Case Study Background

Part 1: Sustainability for an AM Facility

- There is now a greater appetite for these kind of solutions and broad alignment with MTC, HMVC and UK Government strategies for moving towards more sustainable manufacturing and tackling climate change.
- With the global target of reaching Net Zero by 2050 and warnings of the carbon footprint impact of AM from different bodies, there is now a **focus on improving the environmental performance of AM facilities**.
- The new NCAM Metal Powder Bed Fusion (MPBF) Facility is a unique space for showcasing the full AM process chain. This became the test bed for the research and case study.

Case Study Background

Part 1: Sustainability for an AM Facility

The aims of the case study:

- Understand the typical usage of resources within the Metal Powder Bed Fusion (MPBF) cell.
- Identify areas for improvement to target with sustainable solutions.

Case Study Approach

Part 1: Sustainability for an AM Facility

1. *Project Boundaries*: Setting the in- / out-of-scope
2. *Process Mapping*: Identify the process chain(s) that are in-scope
3. *Data Collection*: Find and collect all relevant information and data
4. *Current State Analysis*: Review and analyse the information collected
5. *Reflection*: Report back on the findings

Case Study: Process Map

Part 1: Sustainability for an AM Facility

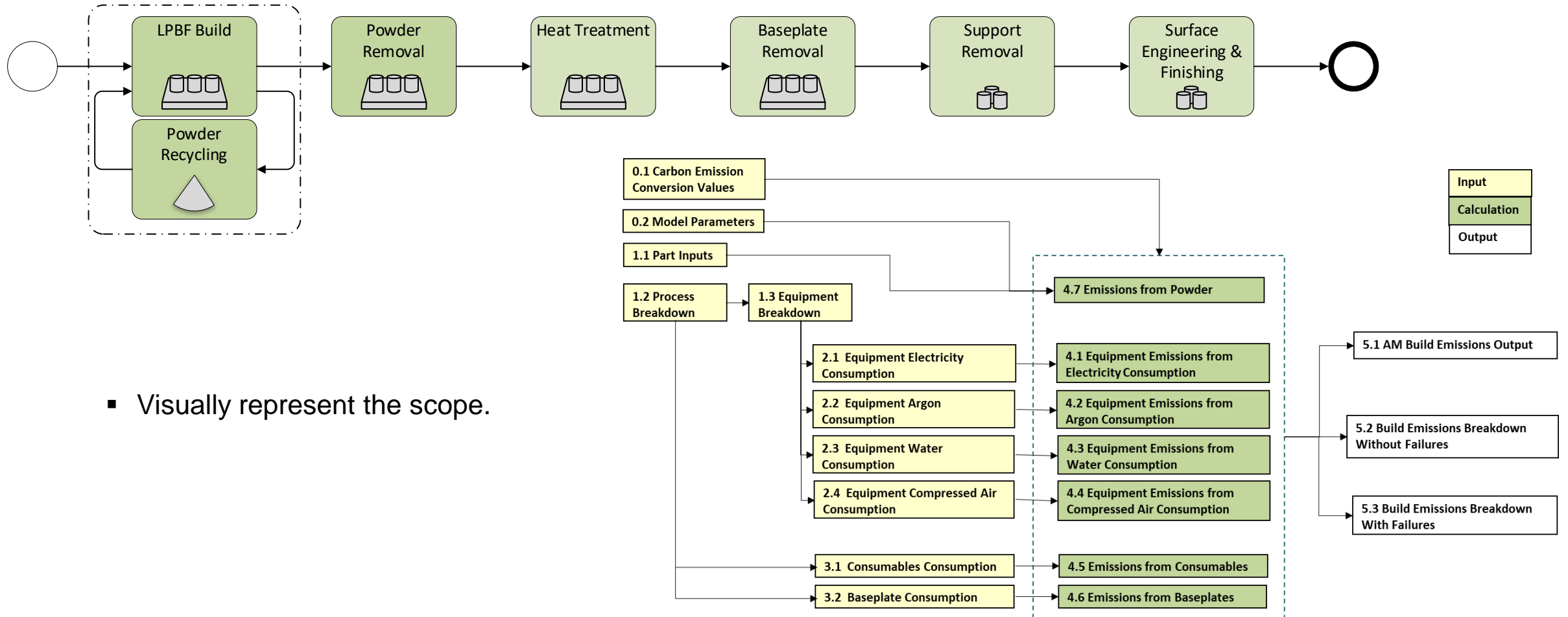

Data Types and Sources

Part 1: Sustainability for an AM Facility

Data to Capture:

- **Powder**
- Consumables
- Electricity
- **Energy**
- Industrial Gases (e.g. Argon)
- Water
- Compressed Air
- Etc.

Data Sources:

- Work Instructions
- Consumables log
- Production packs
- Internal powder tracker
- **Equipment technical specifications**
- Machine logs
- **Facility meters**
- **Academic papers**
- Government published information
- Etc.

Case Study: Data

Part 1: Sustainability for an AM Facility

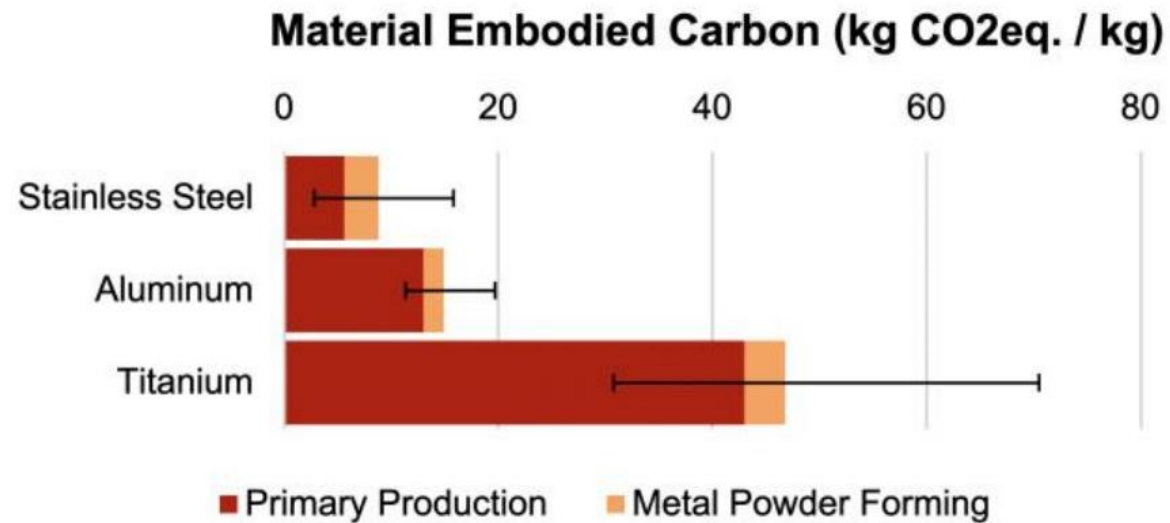

Figure A: Embodied carbon of AM powders [2]



Figure B: Specific Energy Consumption (SEC) of AM processes for different materials [3-7]

Case Study: Data

Part 1: Sustainability for an AM Facility

Example:

- STAN2 Material Flow analysis software [8,9]
- Energy Data from various machines
- Listed out the assumptions & split output by idle and active power usage
- Long time idles meant large idle energy consumption

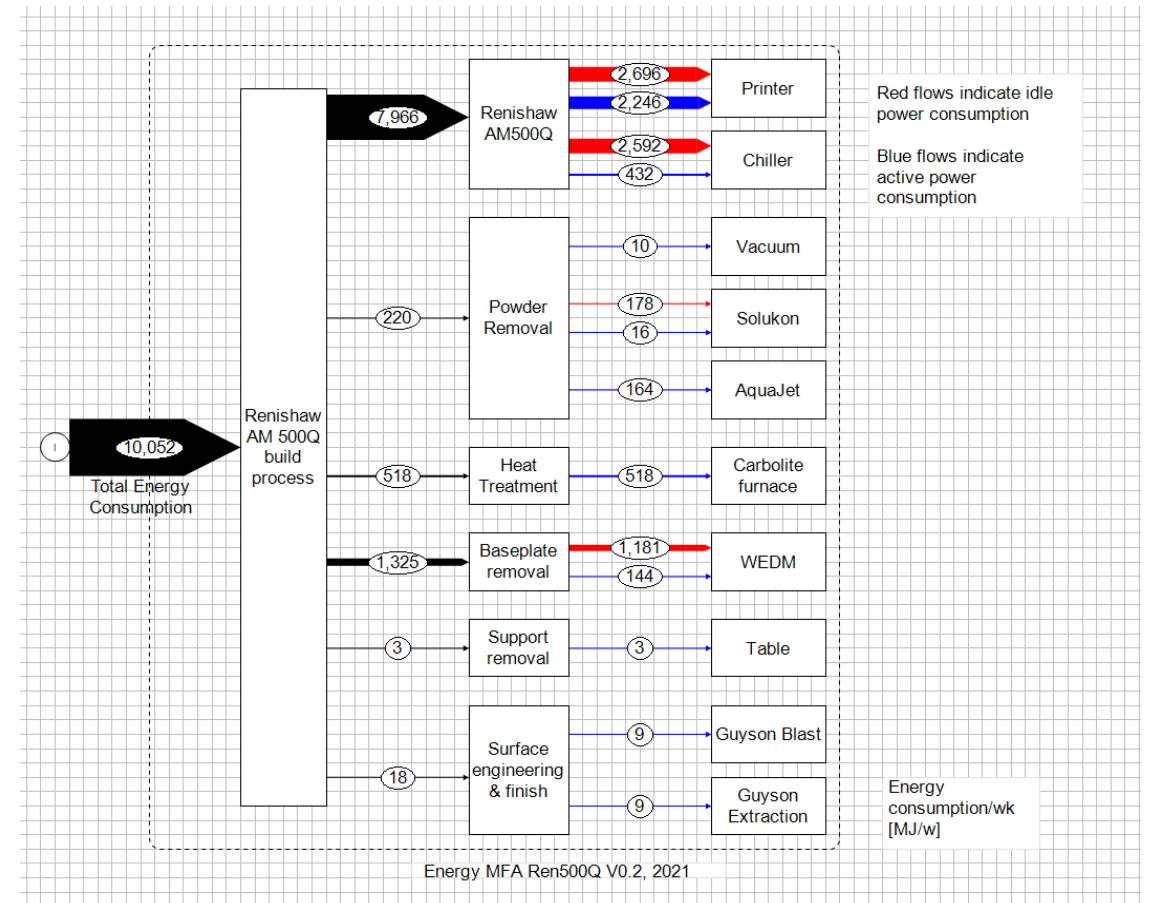

Figure C: Material Flow Analysis Diagram for Energy

Case Study: Carbon Emission Data Model – Baseline Results

Part 1: Sustainability for an AM Facility

- Embodied carbon from primary production of consumables made up the largest proportion of CO₂.
- Electricity from equipment (including ancillaries) is the second largest contributor with AM build responsible for the majority.
- Embodied carbon from primary production of metal powder is also a significant factor.

	Emissions (kgCO ₂ e)
Emissions per Build	832.70
Emissions per Build (consumables omitted)	245.11
Emissions per kg	387.30
Emissions per kg Built (consumables omitted)	114.00

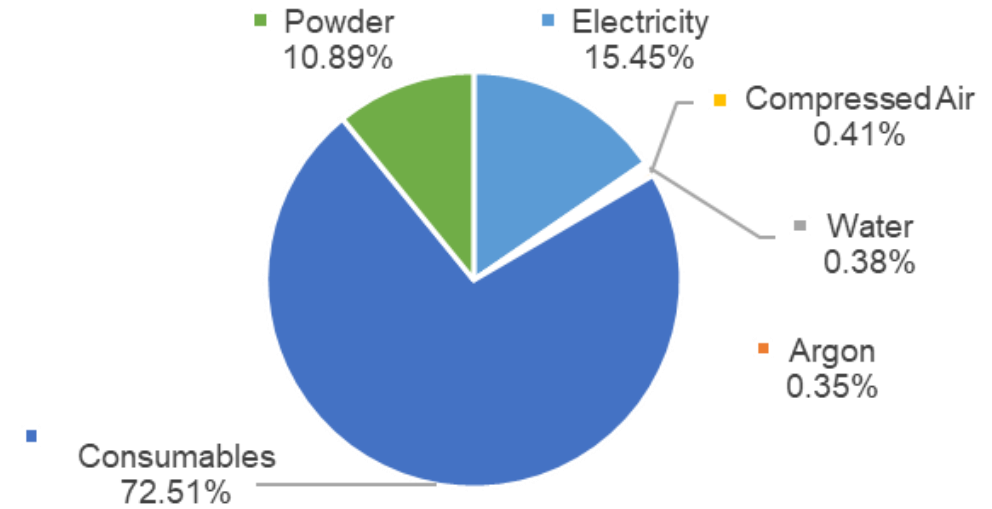

Figure E: Breakdown of carbon emissions by factor

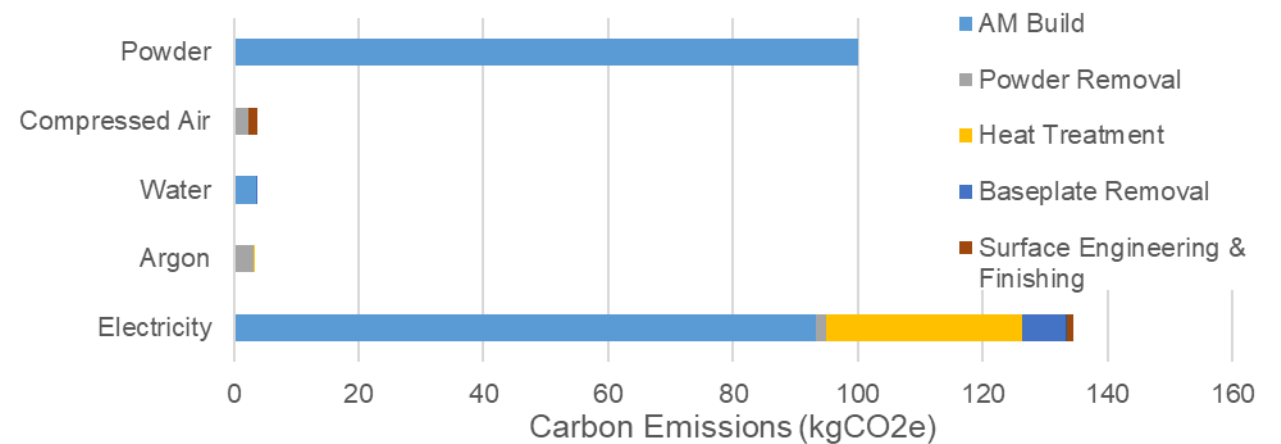

Figure F: Breakdown of carbon emissions by process step and factor (consumables omitted)

Case Study: Carbon Emission Data Model – Change of Geometry Results

Part 1: Sustainability for an AM Facility

- A comparison of carbon impact between scenarios 1 and 2 (two different builds).
- This result is consistent with findings from literature [3,4].

	Scenario 1	Scenario 2
Total Build Mass (kg)	2.15	0.2
Build Height (mm)	108.25	17.5
Build Time (Hours)	13.05	1.15

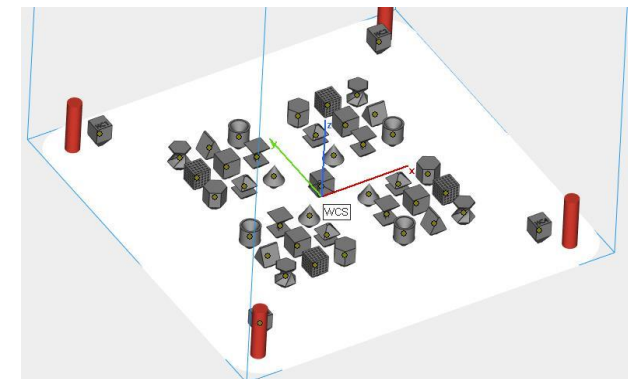
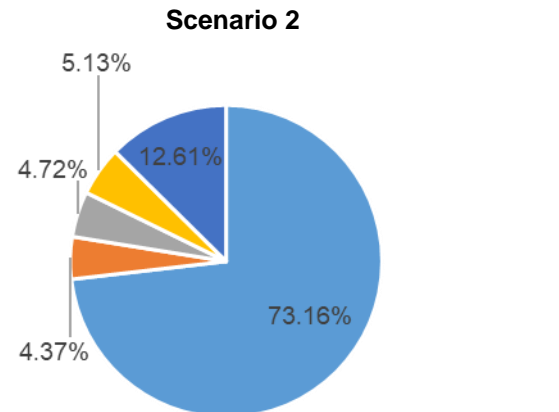
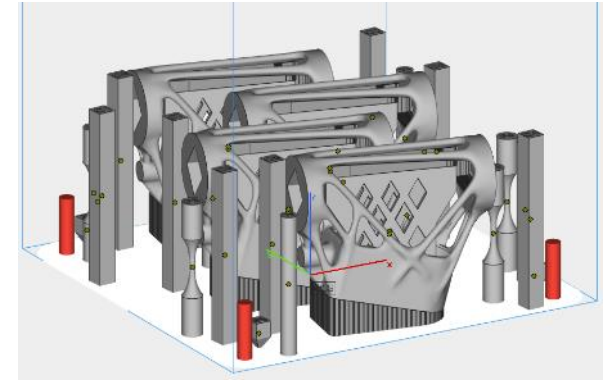
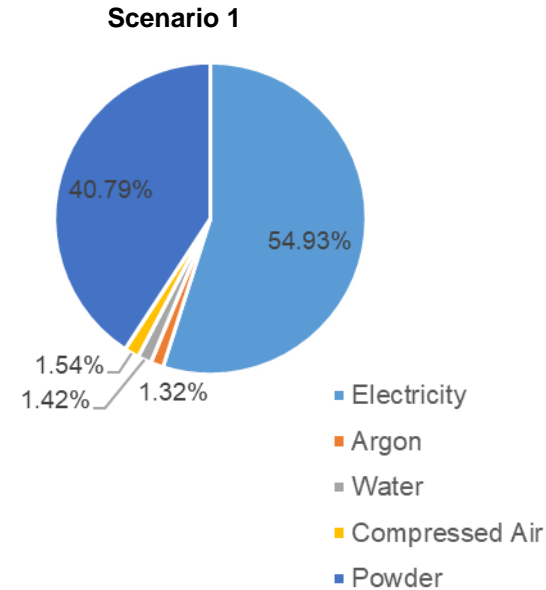

Figure G: Breakdown of carbon emissions by factor

Case Study: Carbon Emission Data Model – Summary of Results

Part 1: Sustainability for an AM Facility

Changes against the Baseline Scenario

- Scenario – ‘Worst case’ (baseline, powder loss and AM build failure rates): *434 kgCO₂e total*
- Scenario – ‘Best case’ (encompassed all previous): *200 kgCO₂e total*
- Mainly due to:
 - Exclusion of powder loss & AM build failure rates,
 - Replacing W-EDM with less intensive removal techniques, this alone reduces the carbon impact by ~3 kgCO₂e. This is consistent with the 2 – 9 kgCO₂e quoted in [3].
- Scenario - Consumables conversion factor (2.1 to 1): significant impact and highlighted the need to better understand consumables consumption.
- Scenario – Build failures (1 in 10 builds): **+32%**
- Scenarios – 20% powder loss: **+8%**

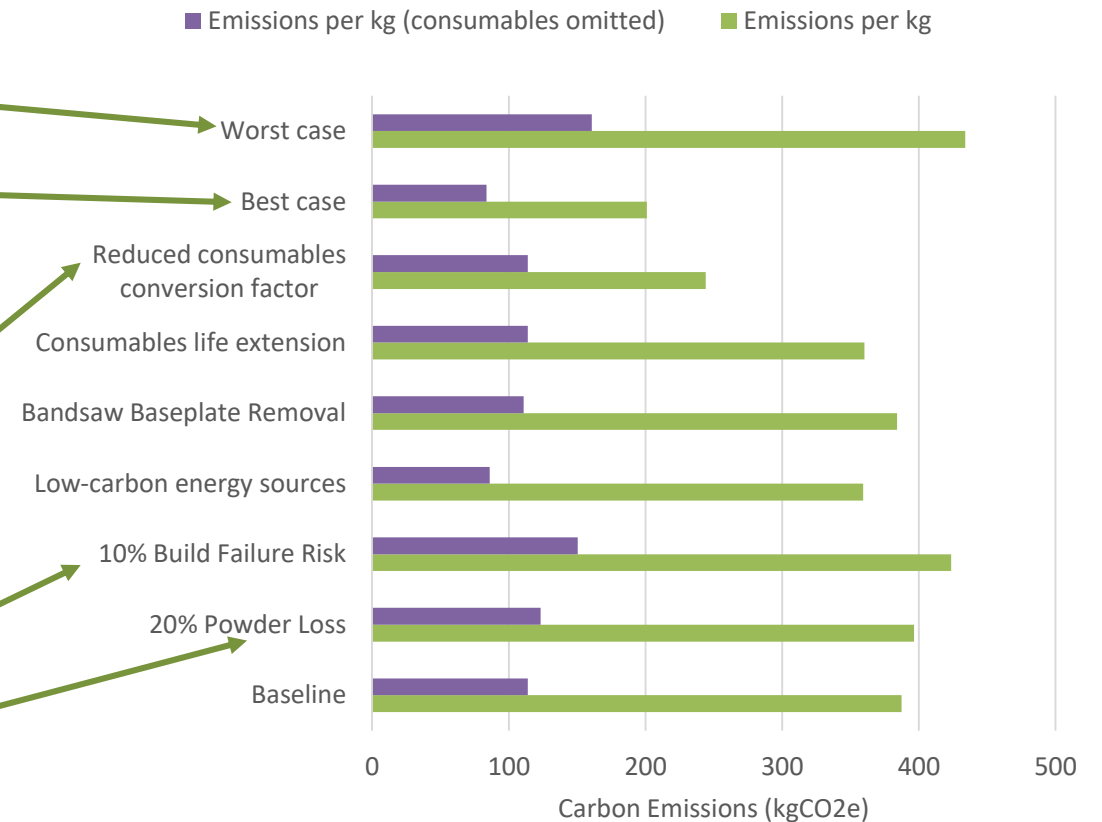
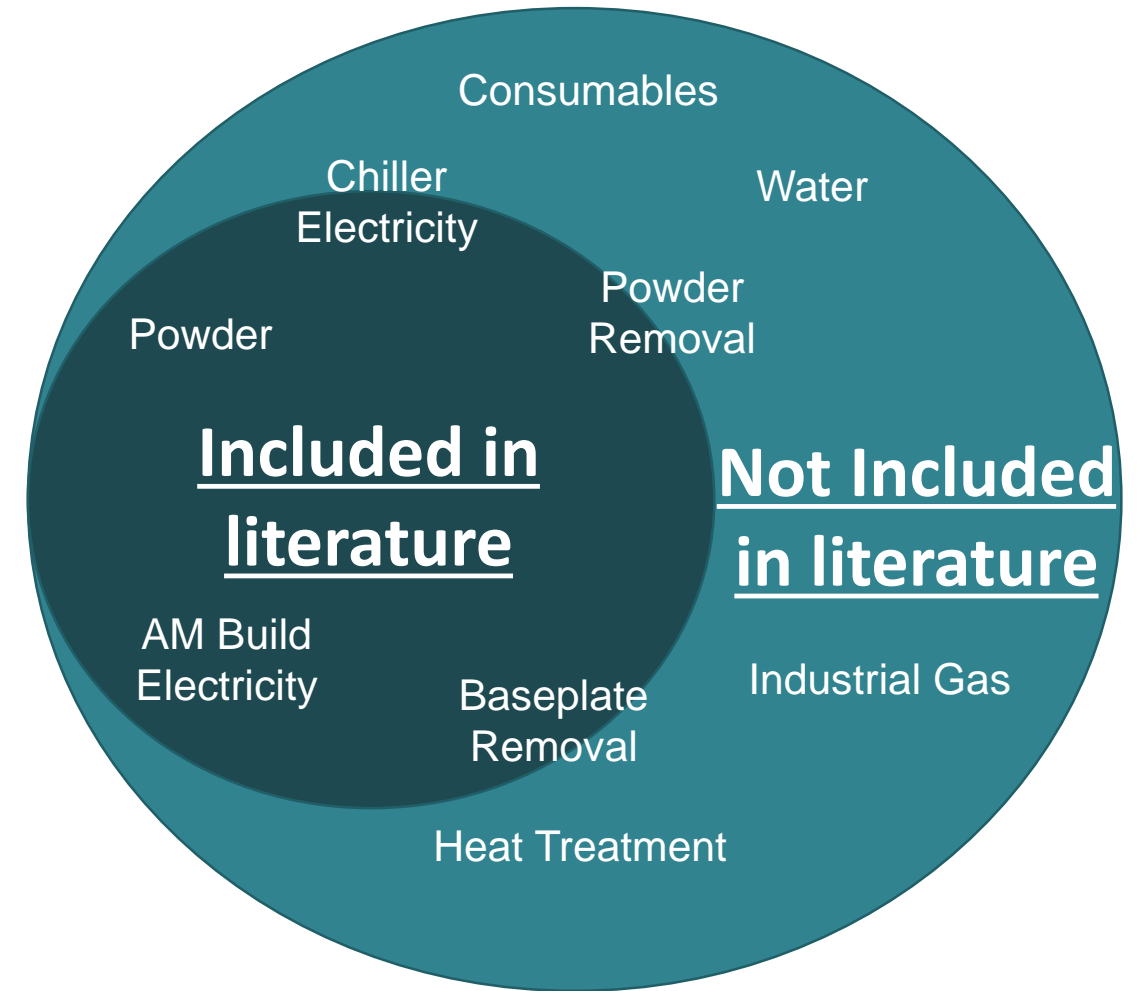

Figure H: Scenario results for carbon impact

Findings

Part 1: Sustainability for an AM Facility

- The carbon emissions predicted by the model are significantly higher than the literature values due to:
 - Different scopes, machine and material
- Consumables are not included in any of the studies reviewed:
 - Consumable emissions were assumed to be proportional to cost.
 - May still be a key contributing factor and should not be ignored in future studies.
- Equipment power in the model was an order of magnitude greater than typical literature values [3-7].
 - Assumed to be a proportion of max power



Part 1: Sustainability for an AM Facility

- Need to understand the sustainability impact of AM in real world situations.
- Data, it's all about what you collect & how you use.
- From the case study: many factors effect the environmental impacts, including the utilisation of the facility.

Morning Overview

- Part 1: Sustainability for an AM Facility
Industrial Case Study
- Break
- **Part 2: Future State for AM**
Exercise
- Break
- Part 3: Sustainability in Design for AM

Exercise

Part 2: Future State for AM

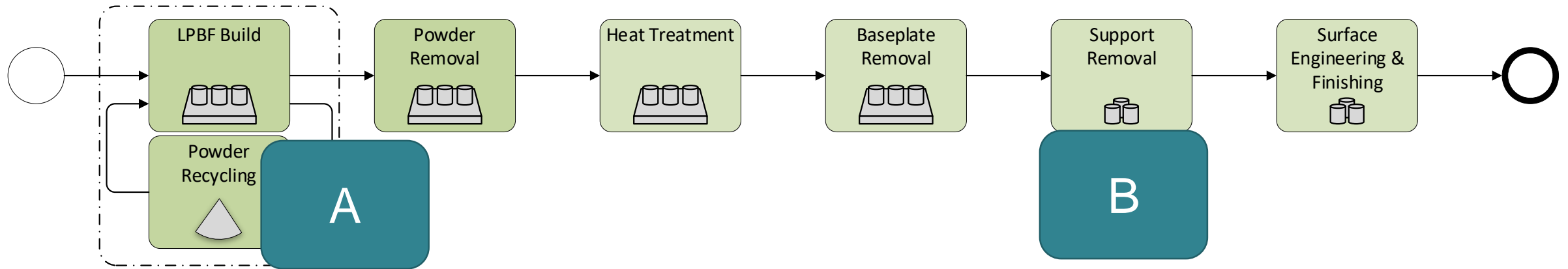

Which are the correct missing steps from the above process flow

1. (A) Baseplate insertion & (B) Part Removal
2. **(A) Powder Recycling & (B) Support Removal**
3. (A) Powder Recovery & (B) Support Removal
4. (A) Baseplate insertion & (B) Part Inspection

Exercise

Part 2: Future State for AM

“What does Blog’s Inc. need to do then?”

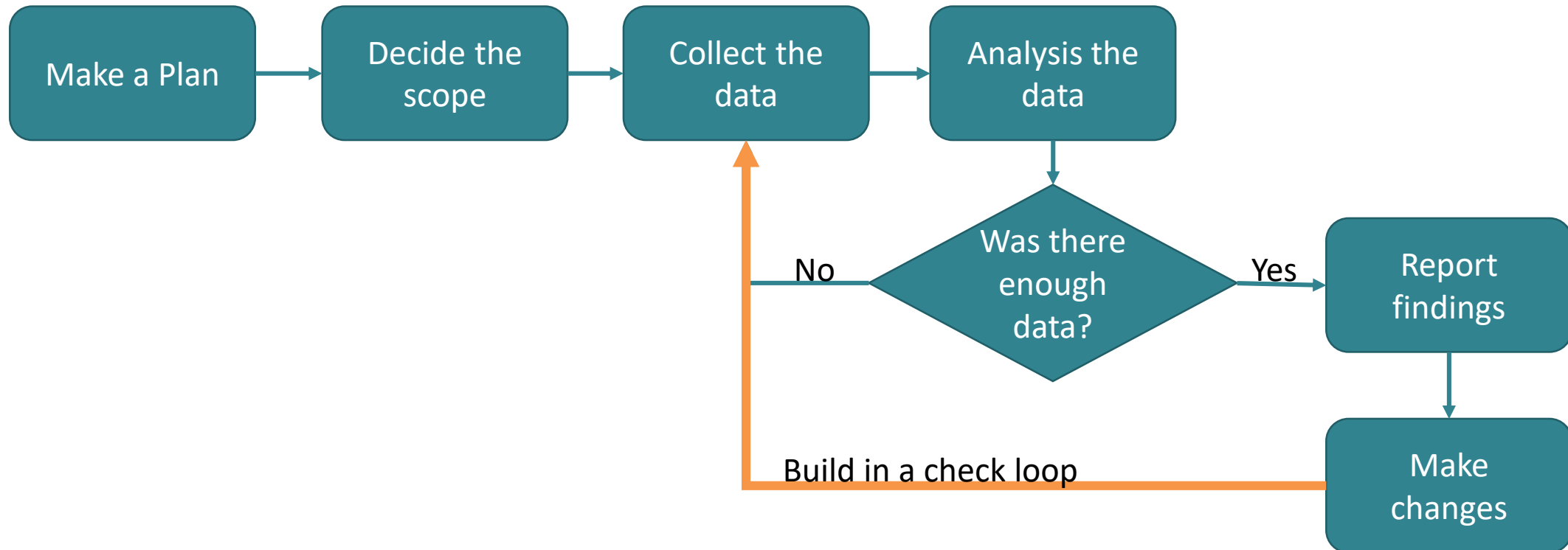

Case Study

Part 2: Future State for AM

Aims

- Review existing and future sustainable solutions from multiple industries for use within AM.

Potential Change Areas

Part 2: Future State for AM

Waste Reduction	Facility: Energy Usage	Powder	General Sustainability
<ul style="list-style-type: none">• Design Optimisation and Simulation Tools• Process Parameter Development• End-of-Life Design Considerations	<ul style="list-style-type: none">• Argon Recycling• Energy<ul style="list-style-type: none">• Supply• Recovery• Control Systems• Facility<ul style="list-style-type: none">• Design• Lifetime	<ul style="list-style-type: none">• Supplier Responsibility• Waste Reduction• Recycling<ul style="list-style-type: none">• Recycling Strategies & Traceability• Material labelling• Powder Rejuvenation• Powder Industrial Symbiosis• Improved Production Methods	<ul style="list-style-type: none">• Waste Points• 3R's• Supply Chain Pressures• Life Cycle Assessments

Process Parameter Development

Potential Change Areas

- Default machine parameters provided by vendors are regularly altered to improve build quality and increase chances of build success, often at the cost of material usage.
- Process/parameter development should be modified to find a middle ground between build consistency and sustainable practices
- Shared data on process parameters and material properties for different geometries would reduce the overall amount of development waste.

Direct Benefit:

- Reduction in failed builds due to better understanding of process parameters
- Reduced powder usage during builds. Waste powder is often recycled, but this costs energy and not all waste can be reused.

How to Implement:

- Change the process development process to also optimise for minimal powder waste.
- Incentives for sharing data and platforms to enable better sharing of data.

Energy Supply

Potential Change Areas

- Switch to low carbon electricity suppliers.
- Suppliers - use of energy to power processes (e.g. recycling facility). sustainable vs. fossil fuels
- The problem:
 - Suppliers are able to buy Renewable Energy Guarantees of Origin without the energy.
 - Essentially able to buy fossil fuel energy and are provided with a matched amount of REGOs per MWh (*megawatt hours*), they can still call themselves green.
 - OFGEM is now considering measures to stop this loophole from happening. [10].



- Direct Benefit:
 - Immediate drop in the emissions associated to the scope 1 & 2 of the facility.
- How to Implement:
 - Research needs to be conducted to determine how the so called “green” energy supplier produces their energy.
 - Research the need to standardise CO₂e energy conversion across the UK and other countries.

Powder Industrial Symbiosis

Potential Change Areas

- Stringent requirements on powder quality (morphology, chemistry, size distribution) particularly in highly-regulated industries such as aerospace
- Powder that is out of specification for LPBF may be acceptable for use in other applications (oversize for EBM / HIP or undersize for MIM / MBJ)
- Recycled powder might be acceptable for building parts with lower-levels of criticality or for other sectors
- Potential to create ecosystem for metal powders and new business models for powder as a service
 - Requires better traceability and transparency of material history
 - Tiered pricing of powder based on history
 - Trusted platforms for powder data management
 - Independent and reputable powder marketplace

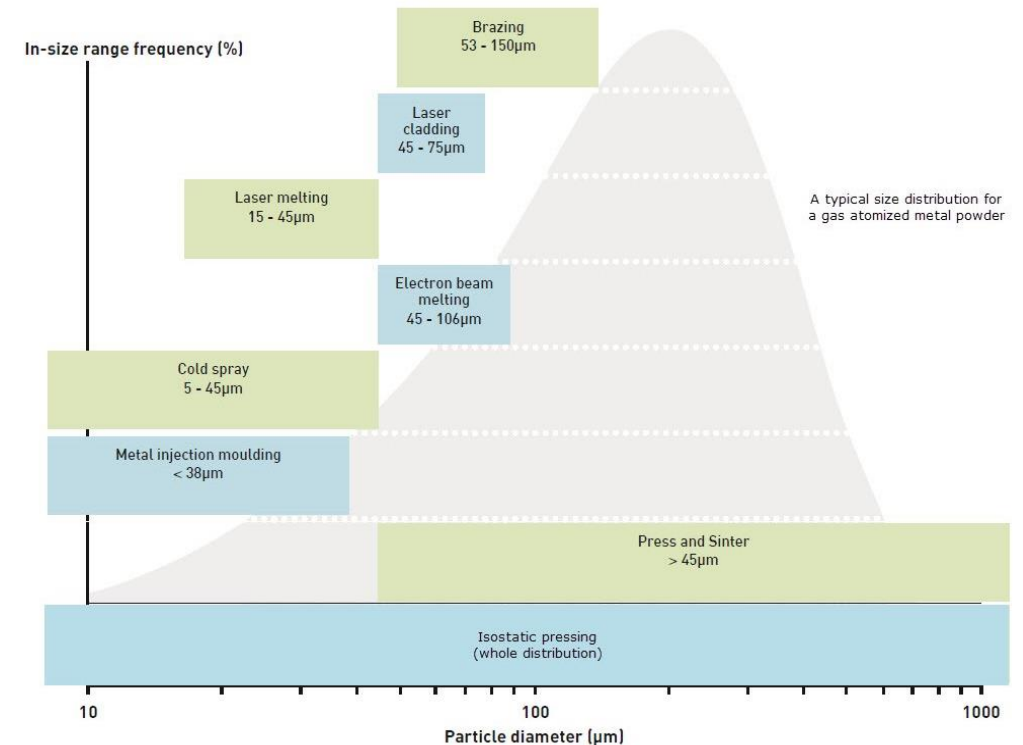

Figure 29: Powder size ranges for different processes [11]

Powder Industrial Symbiosis

Potential Change Areas

Direct Benefit:

- Reduced cost of powder across the supply chain.
- Less raw material required – lower powder carbon footprint.

How to Implement:

- Large collaborative R&D program to prove out concept.
- Other industrial symbiosis systems are known to exist, but costs have not been published for comparison - <https://www.ukmsn.ac.uk/>

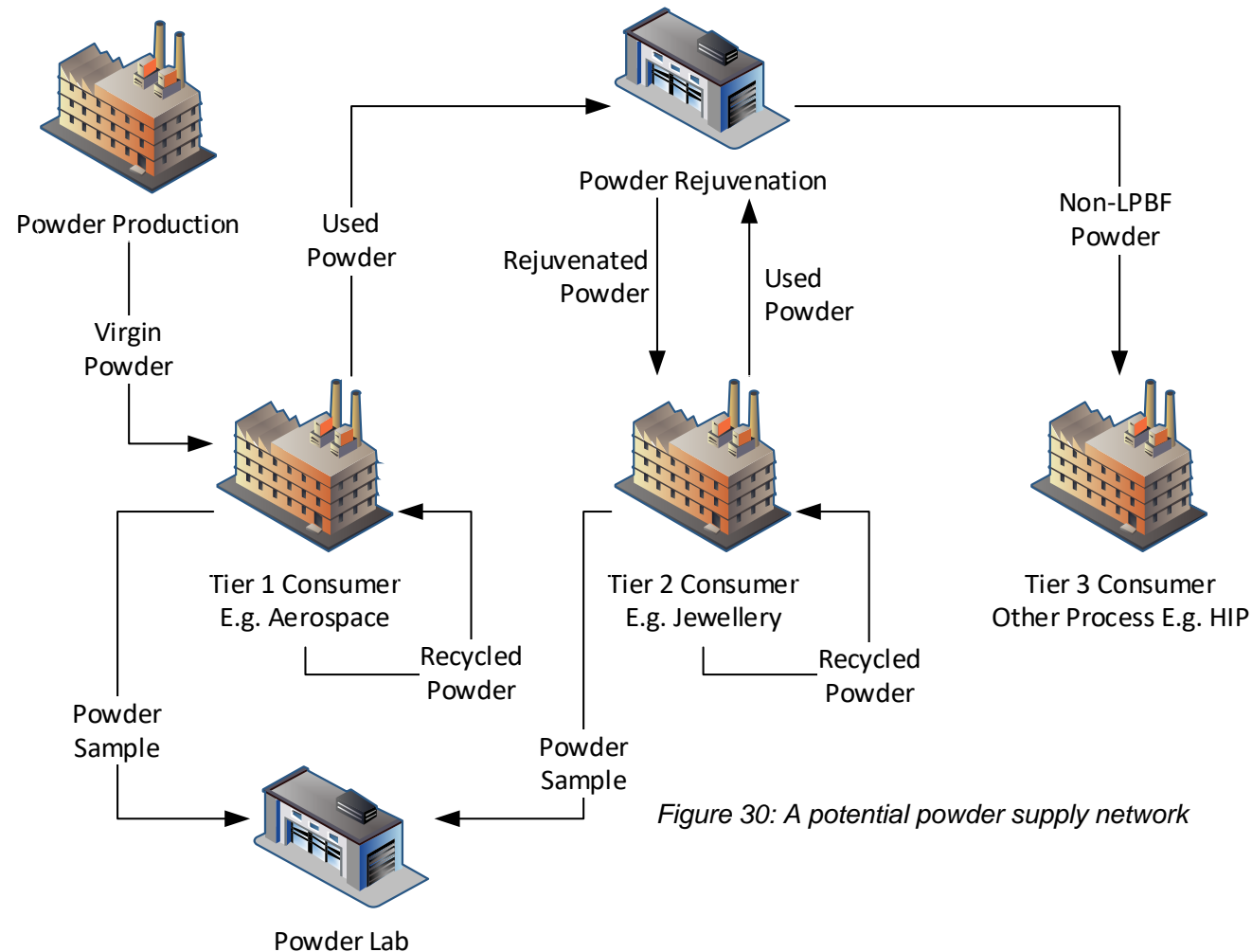
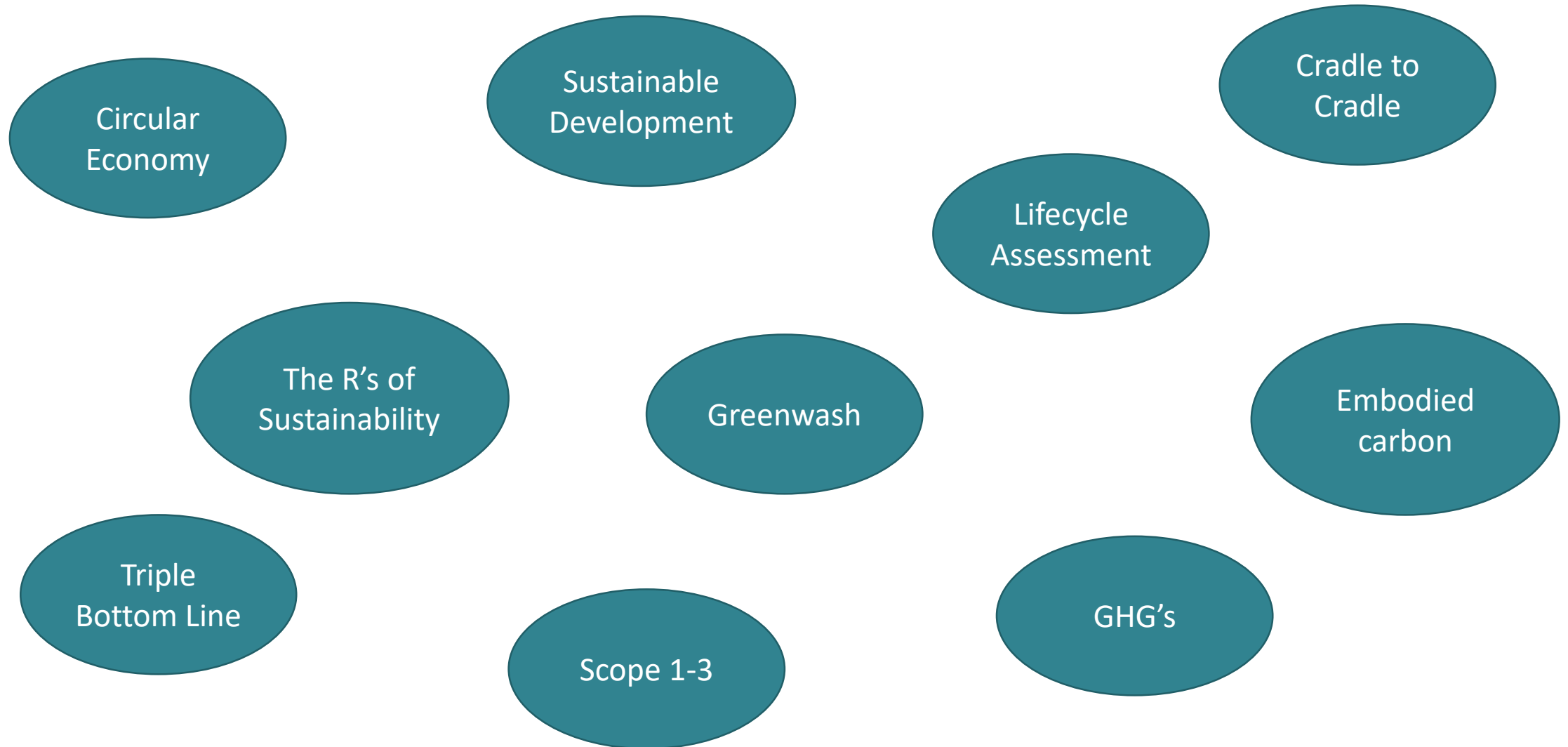

Figure 30: A potential powder supply network

Sustainability and Circular Economy

Part 2: Future State for AM



Sustainability and Circular Economy

Part 2: Future State for AM

- *Circular Economy:*
 - ***A model of production and consumption, which involves sharing, leasing, reusing, repairing, refurbishing and recycling existing materials and products as long as possible. – European Union***
- *Sustainable Development*
 - A process of change in which the exploitation of resources, the direction of investments, the orientation of technological development and institutional change are all in harmony and enhance both current and future potential to meet human needs and aspirations. – The World Commission on Environment and Development, 1987
- *Greenwash:*
 - An attempt to make people believe that your company is doing more to protect the environment than it really is. – Cambridge Dictionary

Part 2: Future State for AM

- Completed practice assessment question.
- Reviewed various different types of existing and future sustainable solutions.
- Considered what this means for you and organisations.

Sustainability & Additive Manufacturing

Round up

- Understand the need for sustainability impact awareness within of AM, in real world situations.
- Begin to consider how data can support environmental impact assessment and what data needs to be collected.
- Reviewed a case study and considered the real world effect on organisations.
- Reflected on various different types of existing and future sustainable solutions.

With thanks to NCAM team for the case study.

DISCLAIMER:

The data contained in this document contains proprietary information. It may not be copied or communicated to a third party, or used for any purpose other than that for which it was supplied, without the MTC's prior written consent ©MTC

References

1. Statista. 2020. *Projected global additive manufacturing market growth between 2020 and 2026*. Available at: <https://www.statista.com/statistics/284863/additive-manufacturing-projected-global-market-size/> (Accessed: 21 September 2021)
2. Van Sice, C. and Faludi, J., 2021. Comparing Environmental Impacts of Metal Additive Manufacturing to Conventional Manufacturing. *Proceedings of the Design Society*, 1, pp.671-680.
3. Faludi, J., Baumers, M., Maskery, I. and Hague, R., 2017. Environmental impacts of selective laser melting: do printer, powder, or power dominate?. *Journal of Industrial Ecology*, 21(S1), pp.S144-S156.
4. Baumers, M., Tuck, C., Hague, R., Ashcroft, I. and Wildman, R., 2010, August. A comparative study of metallic additive manufacturing power consumption. In *Solid freeform fabrication symposium* (Vol. 2009, pp. 278-288).
5. Baumers, M., Tuck, C., Wildman, R., Ashcroft, I. and Hague, R., 2011. Energy inputs to additive manufacturing: does capacity utilization matter. *Eos*, 1000(270), pp.30-40.
6. Baumers, M., Tuck, C., Wildman, R., Ashcroft, I., Rosamond, E. and Hague, R., 2012, August. Combined build-time, energy consumption and cost estimation for direct metal laser sintering. In *From Proceedings of Twenty Third Annual International Solid Freeform Fabrication Symposium—An Additive Manufacturing Conference* (Vol. 13).
7. Kellens, K., Yasa, E., Dewulf, W. and Duflou, J.R., 2010. Environmental assessment of selective laser melting and selective laser sintering. *methodology*, 4(5).
8. Stan2web. 2012. Stan2web. Available at: <https://www.stan2web.net> (Accessed: 21 September 2021)
9. The FAST Standard Association. 2021. Available at: <https://www.fast-standard.org/> (Accessed: 21 September 2021)
10. GREEN SQUARE RENEWABLE ENERGY. 2020. *7 BEST GREEN ENERGY SUPPLIERS FOR 2021*. (13 November 2020) Available at: <https://www.greensquare.co.uk/blog/2020/11/13/7-best-green-energy-suppliers-for-2021> (Accessed: 21 September 2021)
11. Malvern Panalytical. 2021. *Powder metallurgy: Material characterization solutions for metal powders and powder metallurgy*. Available at: <https://www.malvernpanalytical.com/en/industries/advanced-manufacturing/powder-metallurgy> (Accessed: 21 September 2021)

References

12. European Parliament, Circular Economy Definition, (21/03/2022), Available at: [Circular economy: definition, importance and benefits | News | European Parliament \(europa.eu\)](#)